

**SPECIFICATION  
FOR  
LCD Module**

**Customer P/N:**

**Santek P/N: ST0130L1-RSLW-C**

**DOC. Revision: RS01**

**Customer Approval:**

--

	<b>SIGNATURE</b>	<b>DATE</b>
<b>PREPARED BY</b>	Zhiyi Liao	2016-3-16
<b>CHECKED BY</b>	Andy	2016-3-16
<b>APPROVED BY</b>	Natty Lee	2016-3-16

Document Revision History

Version	Revise Date	Description	Changed by
RS01	2016-3-16	Initial release	Zhiyi Liao

Santek / CONFIDENTIAL

---

Table of Contents

1. GENERAL SPEC..... 4

2. MECHANICAL DRAWING.....5

3. INTERFACE DESCRIPTION.....6

4. ABSOLUTE MAXIMUM RATINGS.....7

5. DC CHARACTERISTICS.....7

6. TIMING CHARACTERISTICS.....8

7. BACKLIGHT CHARACTERISTICS..... 11

8. ELECTRO-OPTICAL CHARACTERISTICS..... 11

9. RELIABILITY TEST CONDITIONS AND METHODS..... 14

10. QUALITY STANDARDS..... 15

11. HANDLING PRECAUTIONS..... 16

12. PRECAUTION FOR USE..... 17

1. General Spec

ITEM	STANDARD VALUES	UNITS
LCD type	ST0130L1-RSLW-C	--
Dot arrangement	240 RGB × 240	dots
Color filter array	RGB - stripe	--
Display mode	IPS / Transmissive / Normally Black	--
Viewing direction(Gray inversion)	ALL Direction	--
Driver IC	ST7789V	--
Module size	35.90(W) × 39.70(H) × 1.40(T)	mm
Active area	32.40(H) × 32.40(V)	mm
Dot pitch	0.045(W) × 0.135(H)	mm
Interface	1-lane SPI4-wire interface	--
Operating temperature	-10 ~ +60	°C
Storage temperature	-20 ~ +70	°C
Weight	TBD	g

2. Mechanical drawing

REV 版本	DESCRIPTION 描述	DATE 日期
A01	FIRST ISSUE	JAN.4.2016

PIN ASSIGNMENT	
NO.	
01	LEDA
02	LEDK
03	VDD (.8V)
04	GND
05	VDDIO (1.8V)
06	CS
07	SDI
08	SCLK
09	NC
10	RS
11	RESET
12	GND
13	NC
14	NC
15	NC
16	NC
17	NC
18	NC
19	NC
20	NC
21	NC
22	NC
23	NC
24	NC

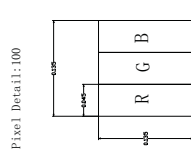
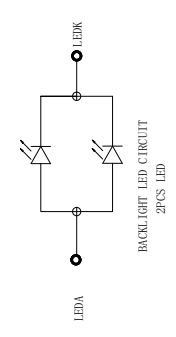
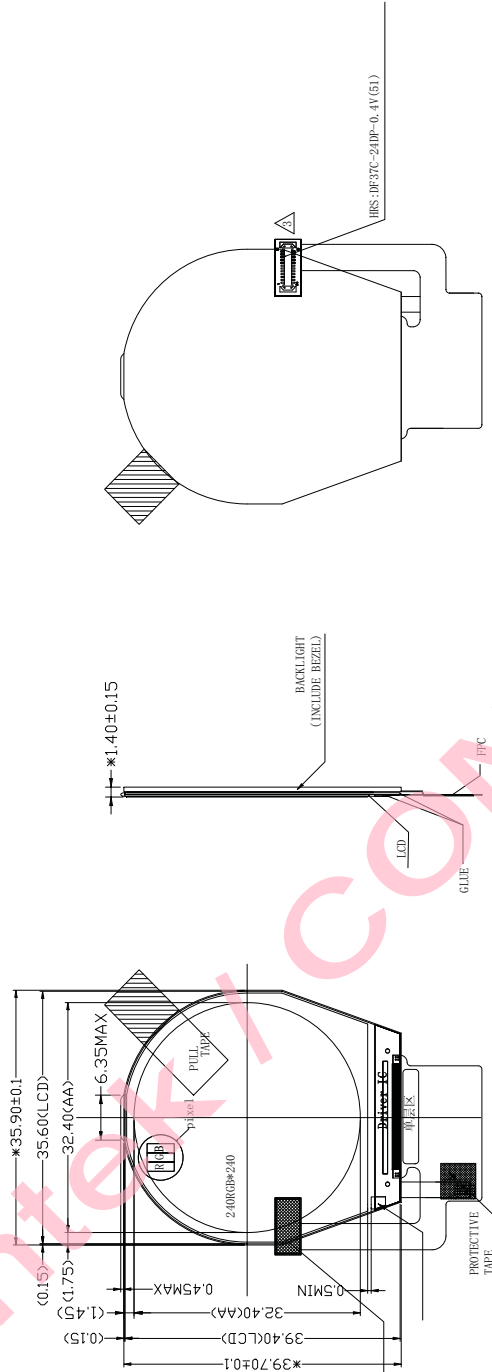

San Technology, Inc.		SCALE: 1:2
Title: TFT		SHEET: 1 OF 1
PARTS NUMBER: ST0130L1-RSLW-C_A01		GENERAL TOL: ±0.3
PARTS CODE:		UNIT: mm
零件编号:		DATE:
DRAWING NO:		APPROVALS:
图号:		APP:
CHK:		CHK:
DWN: Zhiyi		DWN: Zhiyi
2016.1.4		2016.1.4

- NOTES:
- GENERAL TOLERANCE: ±0.2.
  - (...) IS REFERENCE DIMENSION.
  - \* CRITICAL DIMENSION
  - ROHS COMPLIANCE .
  - FRONT POL. IS IPS.; REAR POL. IS IPS-APF.

### 3. Interface Description

No.	Symbol	I/O	Function
1	LEDA	P	Power supply for Backlight.
2	LEDK	P	
3	VDD(2.8V)	P	Power supply for analog and booster circuit.
4	GND	P	Power ground.
5	VDDIO(1.8V)	O	Power supply for I/O system circuit.
6	CS	I/O	Chip selection pin.
7	SDI	I	Serial communication data .
8	SCLK	I	Serial communication clock.
9	NC	I	No connection.
10	RS	I	Display data/command selection pin in 4-line serial interface.
11	RESET	I	Reset control pin .
12	GND	P	Power ground.
13	NC	-	No connection.
14	NC	-	
15	NC	-	
16	NC	-	
17	NC	-	
18	NC	-	
19	NC	-	
20	NC	-	
21	NC	-	
22	NC	-	
23	NC	-	
24	NC	-	

#### 4. Absolute Maximum Ratings

Item	Symbol	Min.	Max.	Unit
Analog Supply Voltage	VCC	-0.3	4.6	V
Logic Supply Voltage	IOVCC	-0.3	4.6	V
Operating Temperature	T <sub>OP</sub>	-10	60	°C
Storage Temperature	T <sub>ST</sub>	-20	70	°C
Storage Humidity	HD	-	90	%RH

#### 5. DC Characteristics

Item	Symbol	Min.	Typ.	Max.	Unit	Remark
System Supply Voltage	VCC	2.4	2.8	3.3	V	-
I/O Supply Voltage	IOVCC	1.65	1.8	3.3	V	-
Input High Voltage	V <sub>IH</sub>	0.7IOVCC	-	IOVCC	V	-
Input Low Voltage	V <sub>IL</sub>	GND	-	0.3IOVCC	V	-
Output High Voltage	V <sub>OH</sub>	0.8IOVCC	-	IOVCC	V	I <sub>OH</sub> =-1.0mA
Output Low Voltage	V <sub>OL</sub>	GND	-	0.2IOVCC	V	I <sub>OH</sub> =1.0mA
I/O Leak Current	ILI	-	-	1	uA	-

## 6. Timing Characteristics

### 6.1 Power ON/OFF Sequence

VIO28 and VIO18 can be applied in any order.

VIO28 and VIO18 can be power down in any order.

During power off, if LCD is in the Sleep Out mode, VIO28 and VIO18 must be powered down minimum 120msec after RESET has been released.

During power off, if LCD is in the Sleep In mode, VIO28 and VIO18 can be powered down minimum 0msec after RESET has been released.

CS can be applied at any timing or can be permanently grounded. RESET has priority over CS.

*Note 1: There will be no damage to the display module if the power sequences are not met.*

*Note 2: There will be no abnormal visible effects on the display panel during the Power On/Off Sequences.*

*Note 3: There will be no abnormal visible effects on the display between end of Power On Sequence and before receiving Sleep Out command. Also between receiving Sleep In command and Power Off Sequence.*

*Note 4: If LSRES line is not held stable by host during Power On Sequence as defined in the sequence below, then it will be necessary to apply a Hardware Reset (RESET) after Host Power On Sequence is complete to ensure correct operation. Otherwise function is not guaranteed.*

The power on/off sequence is illustrated below

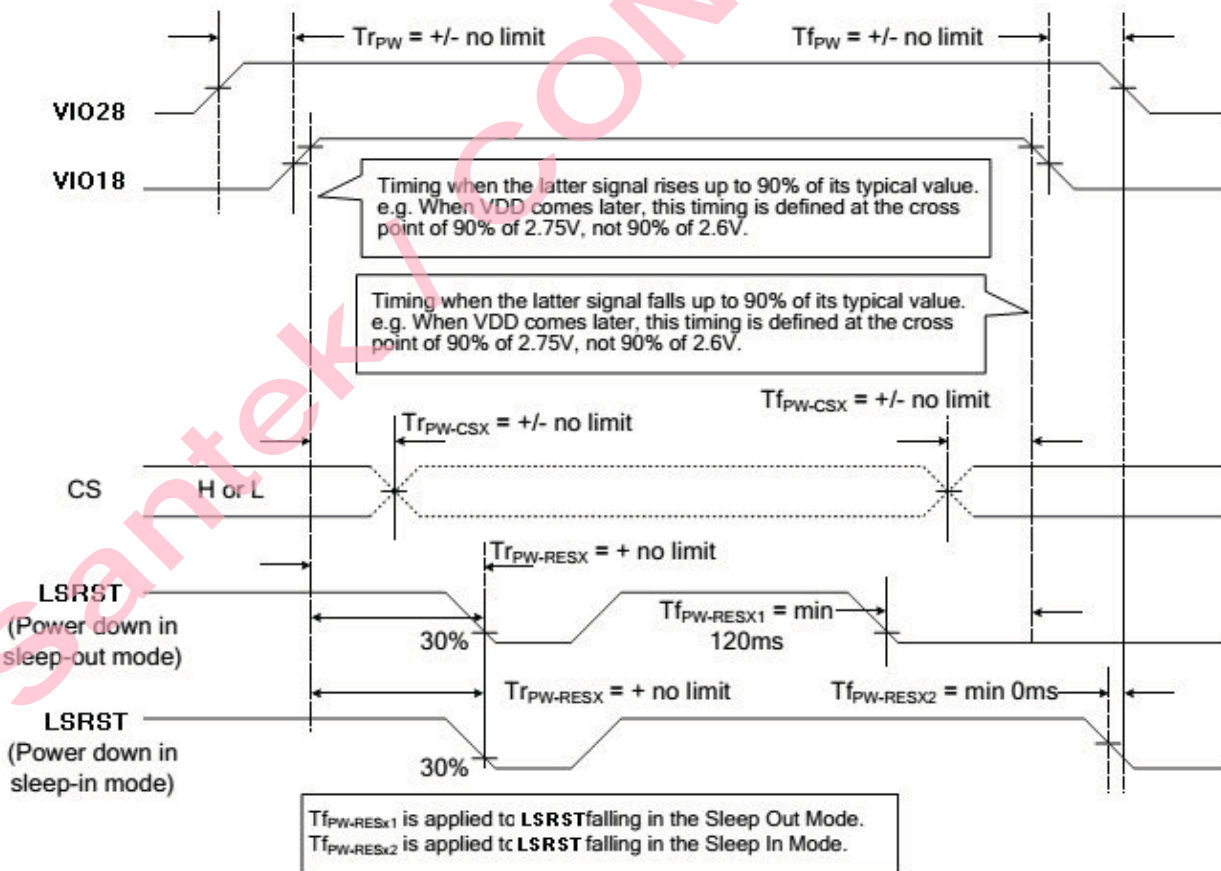



**Uncontrolled Power Off**

The uncontrolled power-off means a situation which removed a battery without the controlled power off sequence. It will neither damage the module or the host interface.

If uncontrolled power-off happened, the display will go blank and there will not any visible effect on the display (blank display) and remains blank until “Power On Sequence” powers it up.

**6.2 Send data Sequence**

The write mode of the interface means the micro controller writes commands and data to the LCD driver. In 4-lines serial interface, data packet contains just transmission byte and control bit D/CX is transferred by the D/CX pin. If D/CX is “low”, the transmission byte is interpreted as a command byte. If D/CX is “high”, the transmission byte is stored in the display data RAM (memory write command), or command register as parameter.

Any instruction can be sent in any order to the driver. The MSB is transmitted first. The serial interface is initialized when CSX is high. In this state, SCL clock pulse or SDA data have no effect. A falling edge on CSX enables the serial interface and indicates the start of data transmission.

**4-line serial data**

stream format: Transmission byte (TB) may be command or data

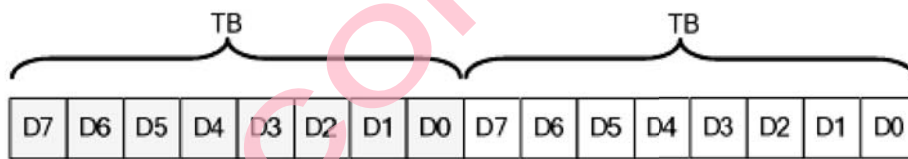
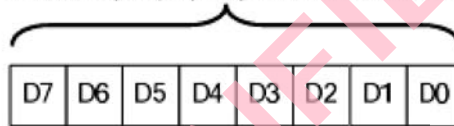

**Serial interface data stream format**

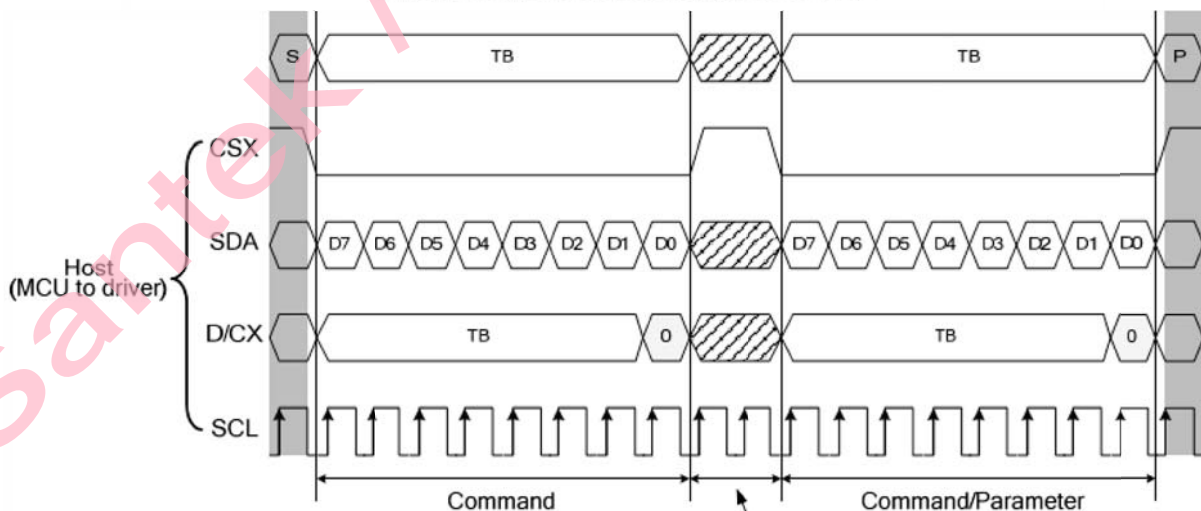

CSX can be “H” between parameter/command and parameter/command SCL, and SDA during CSX=“H” is ignored.

**4-line serial interface write protocol (write to register with control bit in transmission)**

When CSX is “high”, SCL clock is ignored. During the high period of CSX the serial interface is initialized. At the falling edge of CSX, SCL can be high or low. SDA is sampled at the rising edge of SCL. D/CX indicates whether the byte is command (D/CX=’ 0’ ) or parameter/RAM data (D/CX=’ 1’ ). D/CX is sampled when 8th rising edge of SCL. If CSX stays low after the last bit of command/data byte, the serial interface expects D7 of the next byte at the next rising edge of SCL..

### Read function

The read mode of the interface means that the micro controller reads register value from the driver. To achieve read function, the micro controller first has to send a command (read ID or register command) and then the following byte is transmitted in the opposite direction. After that CSX is required to go to

high before a new command is send (see the below figure). The driver samples the SDA (input data) at rising edge of SCL, but shifts SDA (output data) at the falling edge of SCL. Thus the micro controller is supported to read at the rising edge of SCL.

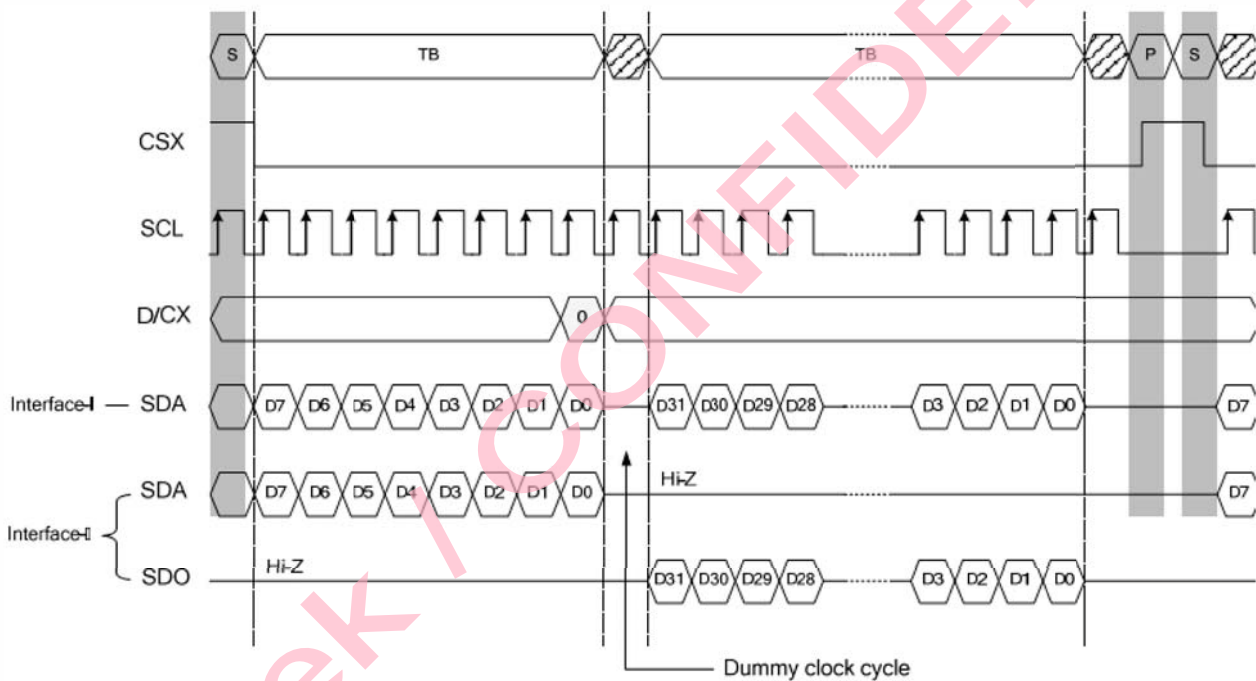

4-line serial interface read protocol

## 7. Backlight Characteristics

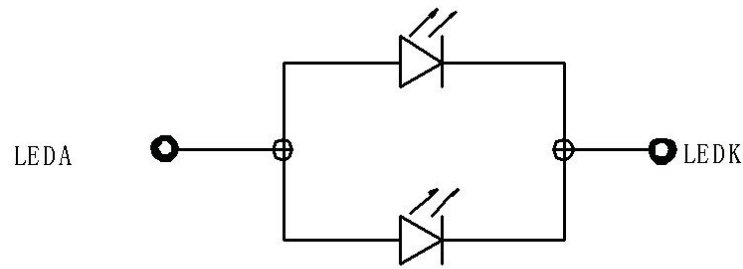

BACKLIGHT LED CIRCUIT  
2PCS LED

Item	Symbol	MIN	TYP	MAX	UNIT	Test Condition
Supply Voltage	Vf	3.0	3.2	3.4	V	If=40mA
Supply Current	If	-	40	-	mA	-
Backlight Color	White					If=40mA

## 8. Electro-optical characteristics

### 8.1 Parameters and specifications

Item	Symbol	Specifications			Unit	Note
		Min.	Typ.	Max.		
Contrast ratio*	Cr ( $\Theta=0^\circ$ )	-	700	-		*[1]Here the data are design value. [2]Chromaticity measuring machine: CA310
Response time (25°C)*	Tr+ Tf	-	35	50	ms	
Viewing angle (Cr≥ 10)*	$\Theta$ 21	60	80	-	deg	
	$\Theta$ 22	60	80	-		
	$\Theta$ 12	60	80	-		
	$\Theta$ 11	60	80	-		
Chromaticity of LCM	Red	x	0.575	0.625	0.675	
		y	0.293	0.343	0.393	
	Green	x	0.288	0.338	0.388	
		y	0.549	0.599	0.649	
	Blue	x	0.106	0.156	0.206	
		y	0.040	0.090	0.140	
White	x	-	0.300	-		
	y	-	0.330	-		
Color gamut of LCM (NTSC%)	S		60.8		%	
Luminous Intensity for LCM	-	-	360	-	Cd/m2	
Uniformity for LCM	-	80	-	-	%	

## 8.2 Definitions and measuring methods

### [1] Response Time(Tr、 Tf)

The rise time ‘Tr’ is defined as the time for luminance to change from 90% to 10% as a result of a change of the electrical condition. The fall time ‘Tf’ is defined as the time for luminance to change from 10% to 90% as a result of a change of the electrical condition.

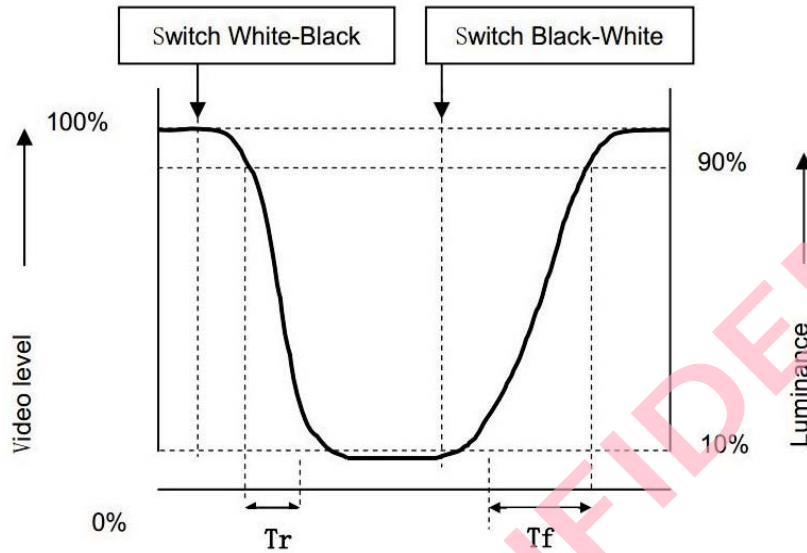

### [2] Contrast ratio (Cr)

The contrast ratio (Cr), measured on a module, is the ratio between the luminance (L\_w) in a full white area (R=G=B=1) and the luminance (L\_d) in a dark area (R=G=B=0):

$$Cr = \frac{L_w}{L_d}$$

### [3] Viewing angle diagram

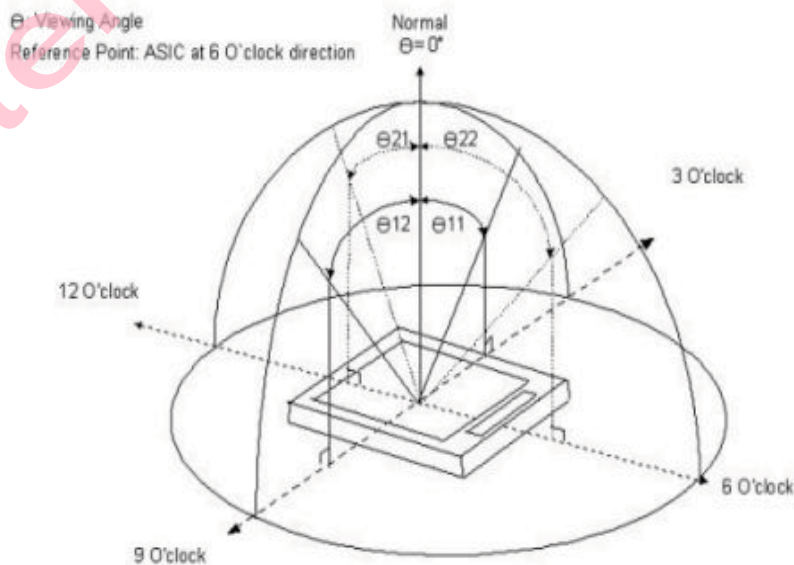

[4] Definition of color gamut

Measuring machine: CFT-01. NTSC'S Primaries: R(x,y,Y)、G(x,y,Y)、 B(x,y,Y).

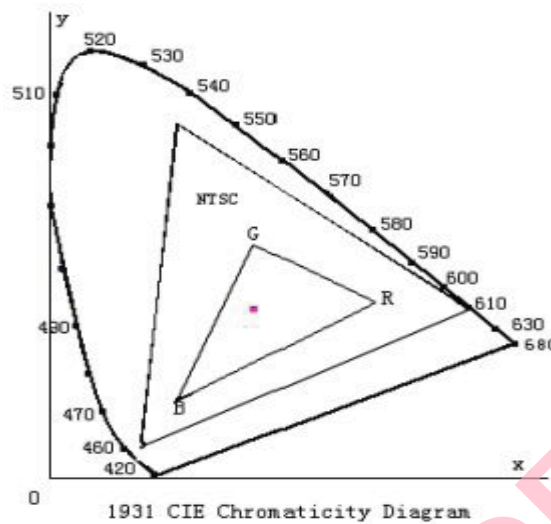

Fig. 1931 CIE chromaticity diagram

$$\text{Color gamut: } S = \frac{\text{Area of RGB triangle}}{\text{Area of NTSC triangle}} \times 100\%$$

[5] Definition of luminance uniformity

Active area is divided into 5 measuring areas, every measuring points is placed at the center of each measuring area.

luminance uniformity=Lmin/Lmax.

L:Active area length .

W:Active area width.

Lmax:The measured maximum luminance of all measurement position.

Lmin :The measured minimum luminance of all measurement position.

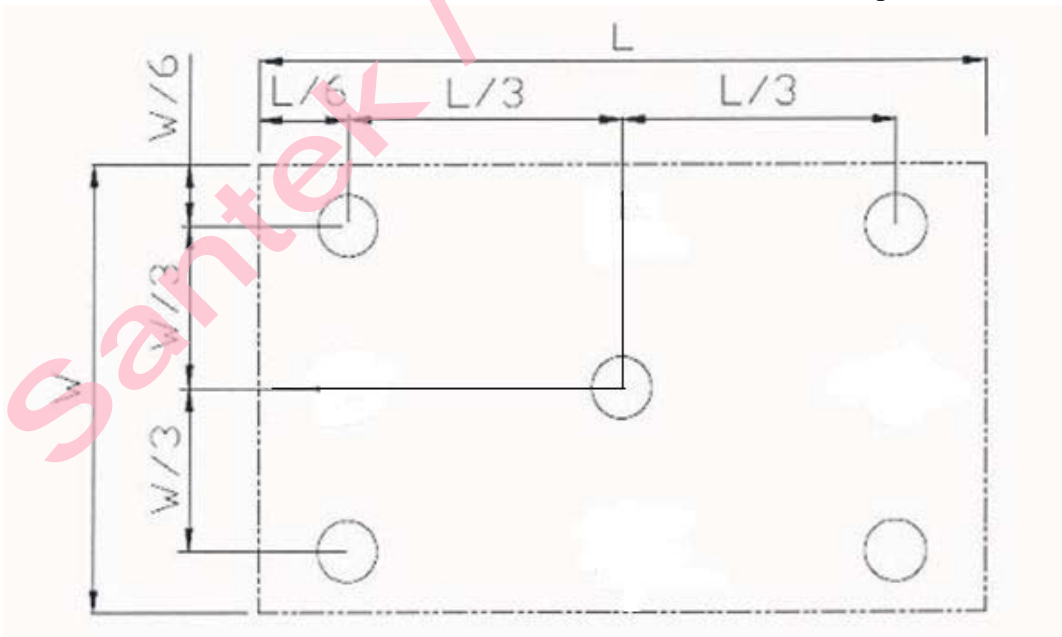

[6] Definition of luminance

Measure the luminance of white state at center point.

**9. Reliability Test Conditions And Methods**

NO.	TEST ITEMS	TEST CONDITION	INSPECTION AFTER TEST
①	High Temperature Storage	70°C×48Hours	Inspection after 2~4hours storage at room temperature,the samples should be free from defects: 1,Air bubble in the LCD. 2,Seal leak. 3,Non-display. 4,Missing segments. 5,Glass crack. 6,Current IDD is twice higher than initial value. 7,The surface shall be free from damage. 8,The electric characteristic requirements shall be satisfied.
②	Low Temperature Storage	-20°C×48Hours	
③	High Temperature Operating	60°C×48Hours	
④	Low Temperature Operating	-10°C×48Hours	
⑤	Damp Proof Test (Storage)	60°C×90%RH×48Hours	
⑥	Temperature cycling(Storage)	-10°C(30min)→25°C(5min)→ 60°C(30min)→25°C(5min) Cycle:5	

**REMARK:**

- 1,The Test samples should be applied to only one test item.
- 2,Sample for each test item is 5pcs.
- 3,For Damp Proof Test, Pure water(Resistance > 10MΩ)should be used.
- 4,In case of malfunction defect caused by ESD damage, if it would be recovered to normal state after resetting, it would be judge as a good part.
- 5,EL evaluation should be excepted from reliability test with humidity and temperature: Some defects such as black spot/blemish can happen by natural chemical reaction with humidity and Fluorescence EL has.
- 6,Failure Judgment Criterion: Basic Specification Electrical Characteristic, Mechanical Characteristic, Optical Characteristic.

**10. Quality standards**

**10.1 Dot defects(operation)**

Item	Size(mm)	Acceptable number	Remark
Bright dots (red / green / blue)	$D \leq 0.1$	Neglected	MI
	$0.1 < D \leq 0.15$	max, 2	MI
	$0.15 < D$	0	MI
Black dots	-	max, 2	Not adjoining black dots
	-	0	adjacent black dots

**10.2 Major defects**

Item	Acceptable number	Remark
Function defect	not allowed	
Abnormal operation including distinct RGB line defects and white line defect	not allowed	
RGB timing	not allowed	
Wrong color	not allowed	
Less brightness	not allowed	
No backlight	not allowed	
Broken glass	not allowed	

**10.3 Minor defects (visual)**

Item	Size(mm)	Acceptable number	Remark
Black spots or white spots	$D < 0.1,$	Neglected	(Note1)
	$0.1 < D \leq 0.2$	max, 2	
	$0.2 < D,$	max, 0	
Black lines, white lines	$W \leq 0.03$	Neglected	(Note2)
	$0.03 < W \leq 0.05$ $L \leq 1,$	max, 2	
	$0.05 < W$	max, 0	

Note1

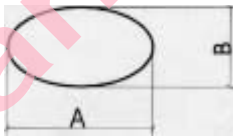

$$D = (A+B) / 2$$

Note2

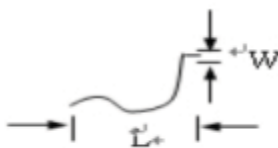

L : length

W : width

## 11. Handling Precautions

### 11.1 Mounting method

The LCD panel of SC LCD module consists of two thin glass plates with polarizers which easily be damaged. And since the module is so constructed as to be fixed by utilizing fitting holes in the printed circuit board.

Extreme care should be needed when handling the LCD modules.

### 11.2 Caution of LCD handling and cleaning

When cleaning the display surface, Use soft cloth with solvent [recommended below] and wipe lightly

- Isopropyl alcohol
- Ethyl alcohol

Do not wipe the display surface with dry or hard materials that will damage the polarizer surface.

Do not use the following solvent:

- Water
- Aromatics

Do not wipe ITO pad area with the dry or hard materials that will damage the ITO patterns

Do not use the following solvent on the pad or prevent it from being contaminated:

- Soldering flux
- Chlorine (Cl) , Sulfur (S)

If goods were sent without being sili8con coated on the pad, ITO patterns could be damaged due to the corrosion as time goes on.

If ITO corrosion happens by miss-handling or using some materials such as Chlorine (Cl), Sulfur (S) from customer, Responsibility is on customer.

### 11.3 Caution against static charge

The LCD module use C-MOS LSI drivers, so we recommended that you:

Connect any unused input terminal to Vdd or Vss, do not input any signals before power is turned on, and ground your body, work/assembly areas, assembly equipment to protect against static electricity.

### 11.4 Packing

- Module employ LCD elements and must be treated as such.
- Avoid intense shock and falls from a height.
- To prevent modules from degradation, do not operate or store them exposed direct to sunshine or high temperature/humidity

### 11.5 Caution for operation

- It is an indispensable condition to drive LCD's within the specified voltage limit since the higher voltage than the limit cause the shorter LCD life.
- An electrochemical reaction due to direct current causes LCD's undesirable deterioration, so that the use of direct current drive should be avoided.
- Response time will be extremely delayed at lower temperature than the operating temperature range and on the other hand at higher temperature LCD's show dark color in them. However those phenomena do not mean malfunction or out of order with LCD's, which will come back in the specified operation temperature.
- If the display area is pushed hard during operation, some font will be abnormally displayed but it resumes normal condition after turning off once.
- A slight dew depositing on terminals is a cause for electro-chemical reaction resulting in terminal open circuit. Usage under the maximum operating temperature, 50%Rh or less is required.



## 11.6 Storage

In the case of storing for a long period of time for instance, for years for the purpose or replacement use, the following ways are recommended.

- Storage in a polyethylene bag with the opening sealed so as not to enter fresh air outside in it . And with no desiccant.
- Placing in a dark place where neither exposure to direct sunlight nor light's keeping the storage temperature range.
- Storing with no touch on polarizer surface by the anything else.  
[It is recommended to store them as they have been contained in the inner container at the time of delivery from us

## 11.7 Safety

- It is recommendable to crash damaged or unnecessary LCD's into pieces and wash off liquid crystal by either of solvents such as acetone and ethanol, which should be burned up later.
- When any liquid leaked out of a damaged glass cell comes in contact with your hands, please wash it off well with soap and water

## 12. Precaution For Use

A limit sample should be provided by the both parties on an occasion when the both parties agreed its necessity. Judgment by a limit sample shall take effect after the limit sample has been established and confirmed by the both parties.

On the following occasions, the handing of problem should be decided through discussion and agreement between responsible of the both parties.

- When a question is arisen in this specification
- When a new problem is arisen which is not specified in this specifications
- When an inspection specifications change or operating condition change in customer is reported to GT LCD , and some problem is arisen in this specification due to the change
- When a new problem is arisen at the customer's operating set for sample evaluation in the customer site.